

SATLOG SLS 4120

Speed Log System

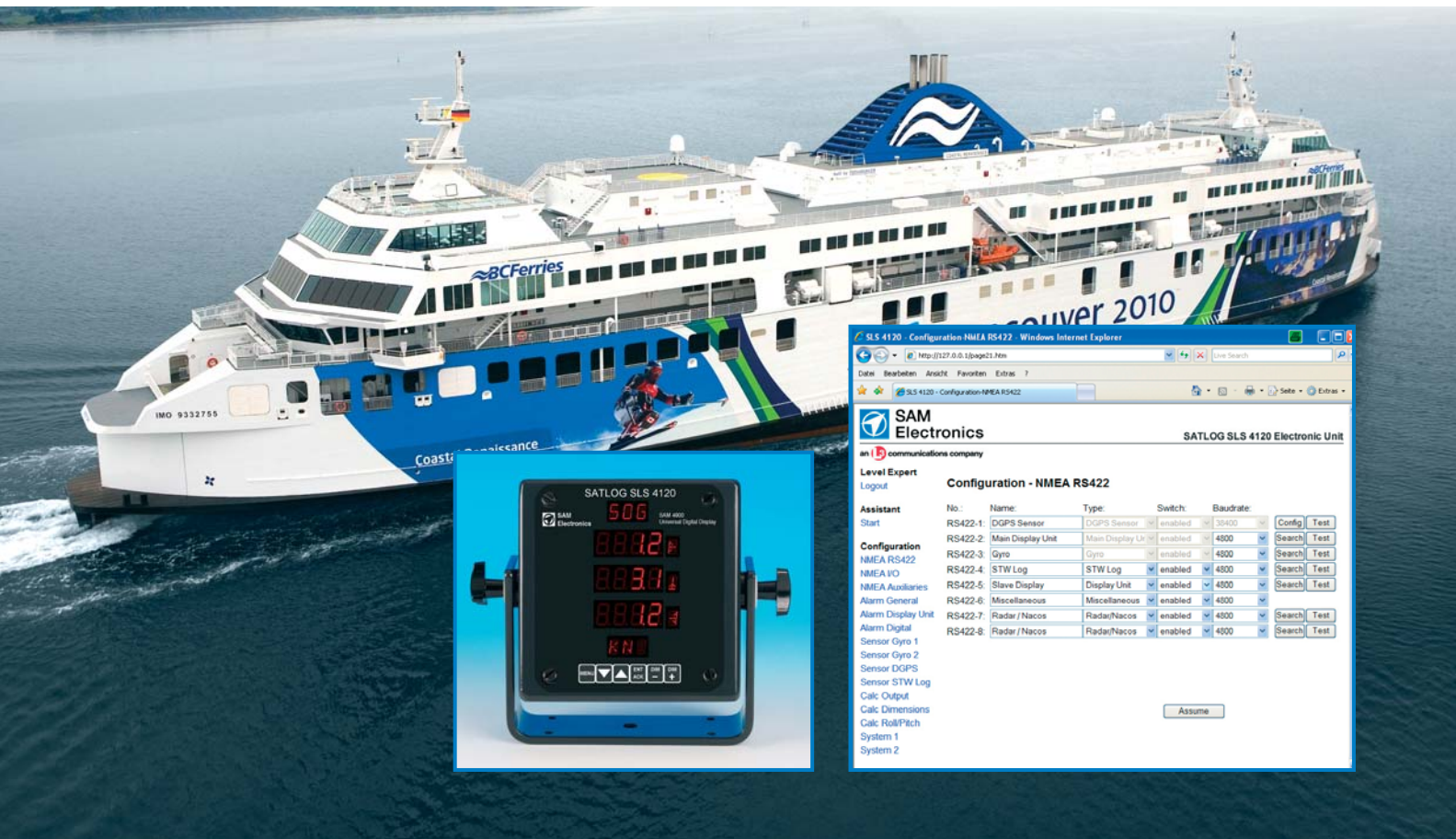

The new Speed Log System SATLOG SLS 4120 measures Speed Over Ground (SOG), referenced to the ship's axes, by using the input from a gyro compass. With a precision of greater than 0.2 knots or 2 % of speed. This accuracy is compliant with the IMO performance standard for Speed and Distance Measuring Devices (SDME) IEC 61023 and allows the SATLOG SLS 4120 to be used as a speed log for ground stabilising applications or docking manoeuvres. Interfaces between the Display Unit, Electronic Unit and DGPS Sensor comply with IEC 61162.

Together with an EM-Log or other log sensor measuring the Speed Through Water (STW), the SATLOG SLS 4120 becomes a central display for speed related information such as Speed Through Water and Speed Over Ground, as well as distances travelled.

Applications

- World wide precise speed determination without differential signals
- High adaptive double-end ferry mode
- Supporting of docking manoeuvres by calculating also the rate of turn and transversal speed at stern by interfacing a gyro compass

- Measurement of Speed Over Ground in the longitudinal and transversal ship direction

Standard Features

- Standard speed accuracy of 0.2 knots
- Speed accuracy of 0.1 knots in differential mode
- Multitrack Differential Beacon Receiver
- Comfortable configuration, maintenance and update of the SLS 4120 via the integrated web interface using a web browser
- Ready for remote maintenance due to the Ethernet interface
- Integrated 24V DC power supply for external components

System Overview

The SLS 4120 is a system for the calculation and visualisation of longitudinal and transversal speed over ground, distance travelled relative to the ground and consists of four components: the Electronic Unit, the Display Unit, the DGPS Sensor and the DGPS Antenna.

Display Unit

The Display Unit is optimised for the intended purpose and consists of several numerical and alphanumerical LED segment displays. 6 keys are available for user input as well as a buzzer for audible warnings. The communication between Display Unit and Electronic Unit is established via a serial interface compliant with IEC 611612-1. Normally

optimised for console mounting, the Display Unit is sized to the international 144 mm x 144 mm Standard. Furthermore a ruggedised housing is available. Display Unit power supply is 24 V DC.

Electronic Unit

The Electronic Unit offers 8 serial interfaces (compliant with IEC 61162-1 and 61162-2) providing information from the DGPS Sensor and Gyro Compass as well as a Speed Through Water Log to send the calculated speed information to the Display Unit. 4 digital relays and 1 digital input to handle different alarm types are available. Additionally the Electronic Unit is equipped with an Ethernet interface for configuration purposes.

The Electronic Unit is supplied with power via its 24 V DC input which also distributes power to the connected components.

DGPS Sensor and Antenna

A common reception of satellite and differential signals are achieved via an all-weather DGPS antenna attached to the DGPS Sensor via a single antenna cable using TNC connectors. The DGPS Sensor is a high-precision GPS receiver with a dual channel beacon receiver for reception of IALA beacon DGPS corrections. The unit performs continuous RAIM calculations, thus enhancing the integrity of position data and attaches to the Electronic Unit for calculating the speed information.

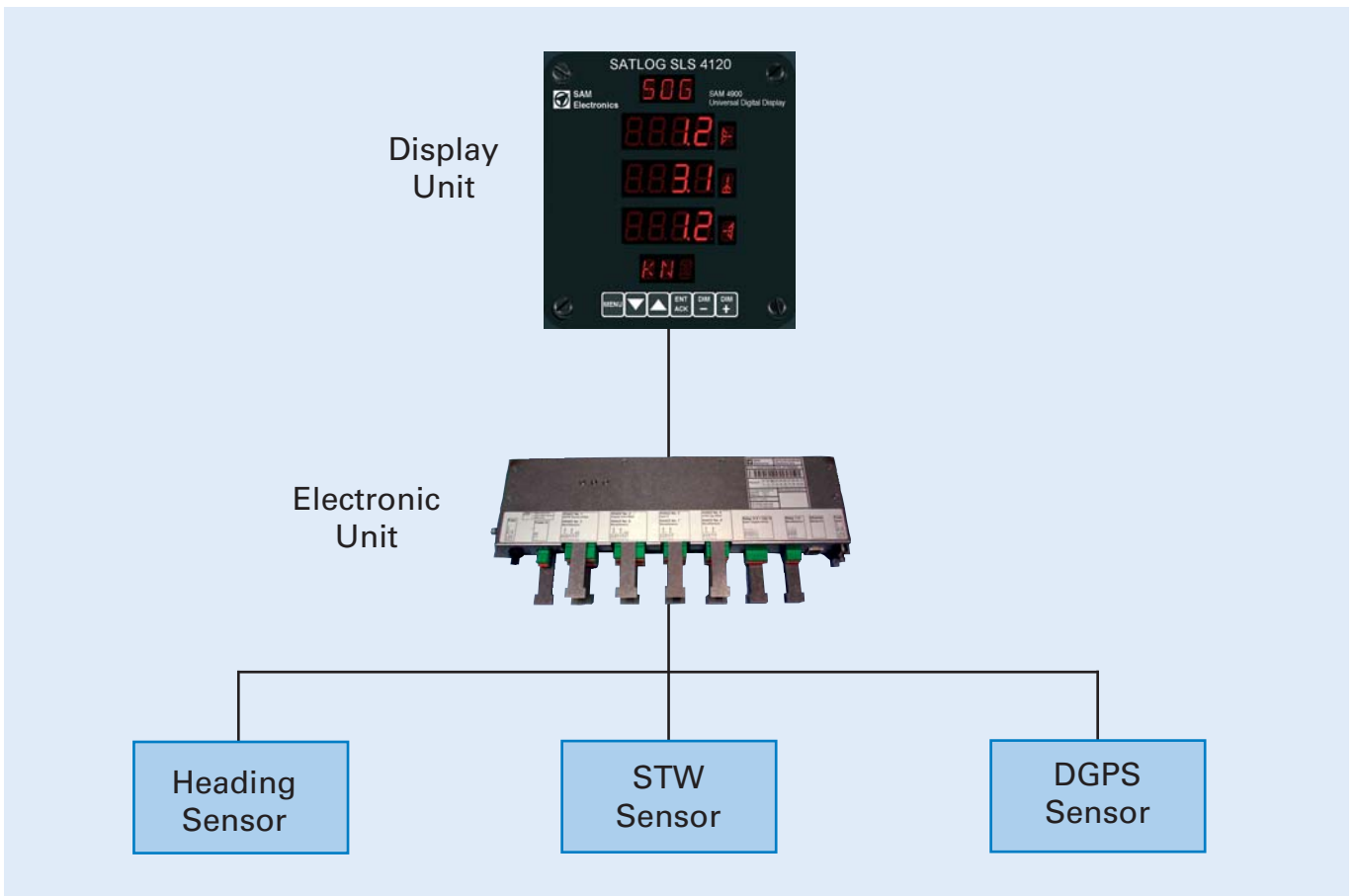

Technical Data

DGPS Performance	
GPS receiver	
12 channel L1, C/A code with carrier phase smoothing	
Update rate	5 Hz
Position accuracy	GPS: 5 m; DGPS: 1m (2d RMS) typical
Cold start	1 min typical
DGPS beacon receiver	
Dual receiver with automatic tuning	
Frequency	283.5 to 325.0 kHz
MSK Bit Rates	50, 100 and 200 bps
Cold start	< 1 min typical
Reacquisition	< 2 seconds typical
Sensitivity	2.5 µV/m for 6 dB SNR at 200 bps
Speed Accuracy	
GPS-only mode	Complies with IMO Res. A.824 and IEC 61023 / 0,2 kn or 2 % whichever is greater
DGPS mode	0,1 kn or 1% whichever is greater
Interfaces	
Serial Ports	8 serial interfaces compliant with IEC 61162-1: <ul style="list-style-type: none"> - 1 port to be used as Display interface - 1 port to be used as DGPS Sensor interface - 1 port to be used as Gyro interface - 1 port optionally to be used as STW-Log interface
Power interface	4 24V DC power supply (max. 1 A) interface for connected equipment
Digital I/Os	4 alarm relays: <ul style="list-style-type: none"> - 2 programmable speed alarm (for rudder system, stabilizers or other applications) - 1 power failure alarm - 1 system failure alarm 1 digital input
Ethernet	1 Ethernet 100 Mbit (RJ45)
Physical & Environmental	
Display Unit	
Supply voltage	24 V DC (supplied from Electronic Unit)
Dimensions	144 mm x 144 mm x 53 mm
Weight	590 g
Electronic Unit	
Supply voltage	24 V DC (+30% / -10%)
Dimensions	406,5 mm x 165,43 mm x 42,25 mm
Weight	1900 g
DGPS Sensor	
Supply voltage	24 V DC (supplied from Electronic Unit)
Dimensions	135 mm x 130 mm x 40 mm
Weight	490 g
DGPS Antenna	
Dimensions	130 mm x 130 mm x 80 mm
Weight	450 g

Technical Data

Compliance with the following standards

IEC 60945 General requirements
IMO Resolution A.694

IEC 61162-1 Digital interfaces- Part 1
IEC 61162-2 Digital interfaces- Part 2
IMO Resolution MSC 96

IEC 61023 Marine speed and distance measuring equipment (SDME)
IMO Resolution A.824

Type Approvals

Requirements according to Marine Equipment Directive (MED), USCG

Display Unit

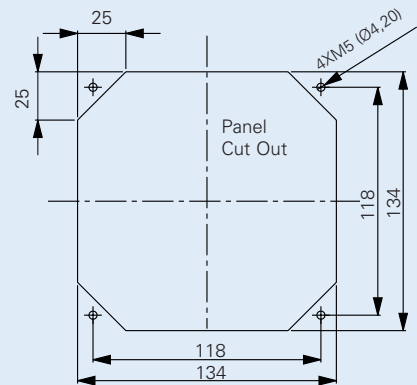
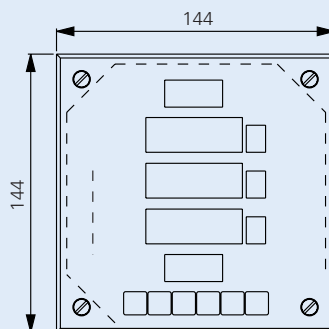
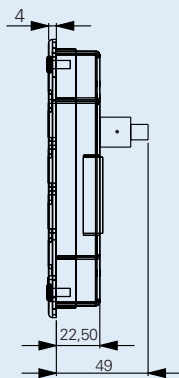
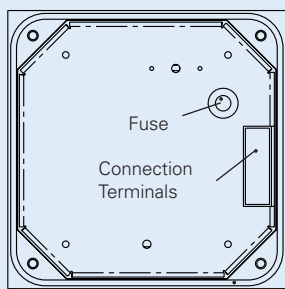

Electronic Unit

