

Compliant
with new
IMO 2008 regulations

RADARPILOT 1100

Brilliant Colour Radars



Introduction

The RADARPILOT 1100 represents a milestone in technical performance, ease of operation, simple maintenance and future oriented system technology.

- Easy to operate by means of trackball
- Compliant with new IMO class 1, 2 and 3 radars
- Wide range of console and desktop options
- Wide choice of X- and S-band transceivers (bulkhead or aloft)
- Two antenna speeds for high speed operations (HSC)*
- Integrated 2-way radar interswitch
- CLEAN SWEEP for automatic suppression of clutter
- Extra window for radarscope, echosounder, wind or docking display
- Display of own chart user objects which are created on the CHARTPILOT 1100
- High resolution colour graphics and monitors provide a clear and distinct radar presentation
- Display of pre-planned routes
- Two metric docking ranges
- Integrated Automatic Steering and Track Control for TRACKPILOT 1100 (in case of NACOS xx-5 only)
- Display of NAVTEX messages
- Tracking of 80 ARPA/AIS targets
- Display of 400 AIS sleeping targets
- ARPA/AIS target association function
- Full operation as minimum keyboard display for AIS 3400/10
- Optional remote access e.g. for wing operation to master each display from any of up to 4 slave stations
- Full operation of Voyage Data Recorder DEGEV 4300 including radar recording

* The high antenna rotation is available with three phase power supply only



Innovative Solutions

The RADARPILOT 1100 sets a new milestone in marine radars. Decades of experience combined with the latest technology open up new dimensions of practical use.

- Take advantage of high resolution graphic performance for clear radar presentation and easy target recognition
- Suppress radar interference from rain or sea clutter simply with the CLEAN SWEEP function: AVE (Automatic Video Enhancement) is now a standard feature
- Experience the advantage of modern graphic processors: Target trails are automatically adopted to signal strength and are not lost even if they are changed in presentation or length
- Make use of intelligent functions for economic and safe navigation, e.g. the novel DOCKING MODE which is implemented in special 250 and 500 m range scales. The additional docking function will assist you with a graphic display of bow and stern distances and speed to the pier
- Switch to high speed antenna rotation¹⁾, this is advantageous for high speed ship operations and improves the display refresh rate for better target recognition
- Access user-friendly navigation function for route planning with courses, safety contours, traffic separation lines and chart symbols
- Observe an enlarged cut-out of the RADARSCOPE function in a separate display window. Or use this for graphic display of wind, depth or docking data
- In combination with DEBEG 2902 NAVTEX messages will be directly reported to the radar and displayed on user demand
- If connected to the VDR DEBEG 4300 the internal network of the RADARPILOT allows direct recording of the radar image
- In combination with the AIS 3400/10 the RADARPILOT supports full AIS operation, which saves the costs for an extra Minimum Keyboard Display



The mechanical housing concept of the RADARPILOT 1100 is very flexible:

- Choice between desktop and console versions
- The monitor and control panel components can also be supplied as individual units for integration into a customer specific console

RADARPILOT 1100

Interswitching of antennas

- for dual installations (via built-in interswitch)
- for multiple installations with up to 5 transceivers/displays (via optional PCI interswitch)

CLEAN SWEEP

Anti-Clutter Optimisation with AVE (Automatic Video Enhancement)

Interference Rejection

Simple maps and symbols can be created by using the radar map editor. If connected to the CHARTPILOT own chart objects can be transferred via LAN to the radar

4 Parallel Index Lines (PI)

for manoeuvre planning

2 Independent EBL and VRM

adjustable individually or combined directly within the PPI or via rotary knobs of the optional keyboard

The **Trackball** is the main operational element. The active field is marked by a frame. A quick info box shows the available operational functions for the trackball buttons. Optional control panels can be integrated for operating the **Radar** or **TRACKPILOT**

Control of the display mode **Head Up** and **North Up** or **RM** and **TM**

Control of the **Radar PPI** e.g. display ranges may be selected from 0.25 to 96 NM or for **DOCKING** as 250 or 500m

Alarm symbol for calling-up of alarm messages

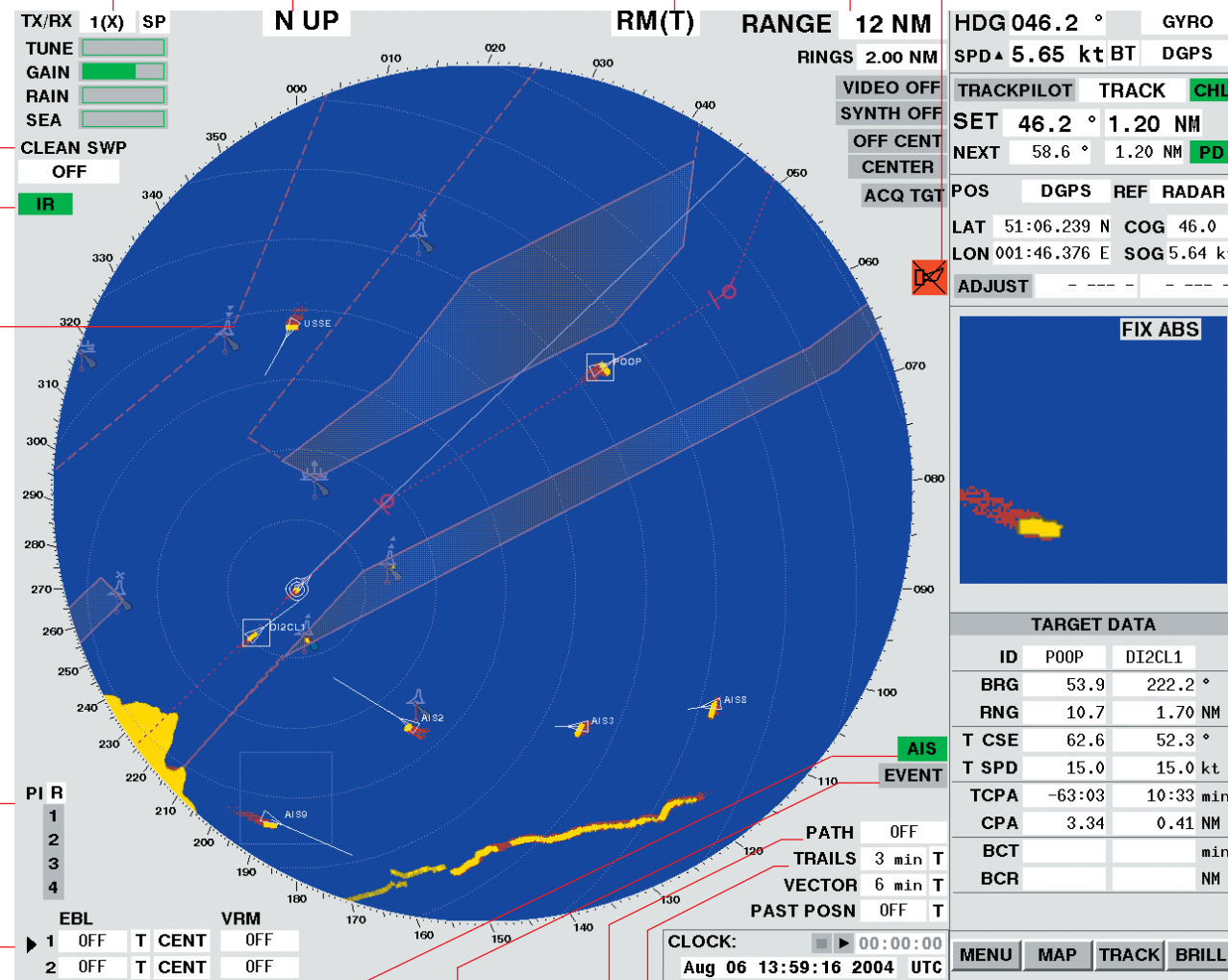

Heading

Speed

TRACKPILOT (Option NACOS) for Heading, Course- or Track Control

Selection of Consistent Common Reference Point (CCRP)

Data of on-screen **cursor position** or own **ship's position** and sensor in use

Radarscope window with display options:

- Radar-zoom fixed to a tracked target or to a certain position
- Graphic display of wind or depth profile
- Docking display
- AIS data display
- Radar map operation menu
- Alarm list

Data display for:

- Full tracked data for two marked targets
- Short readout of up to 8 targets
- Waypoint data
- Track data

Access to track and route planning functions

Individual brightness settings including choice of 6 colour tables

Access to mapping functions

The Radarscope window may alternatively display **WIND** or **DEPTH** graphics, if the respective sensors are connected.

In the **DOCKING** mode the 2nd EBL may be used to establish the initial distances from the bow and stern to a berth. After defining the reference positions of the ship's contour, the **RADARPILOT** continuously displays the actual distance and speed values based on the input of the (D) GPS receiver.

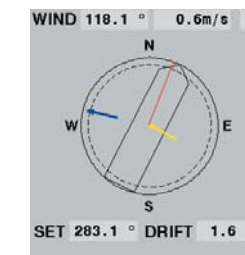

WIND display

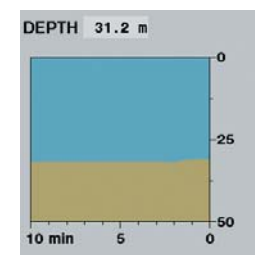

DEPTH display

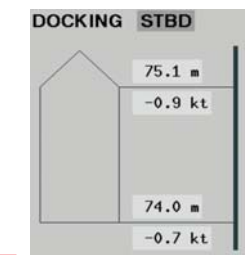

DOCKING display

Display of **AIS** data and symbology

Display and storing of **EVENT** data. **PRINT** screen function via CHARTPILOT 1100

PATH Prediction allows the operator to display a change of heading via constant radius turn

Trails are not lost despite of changing parameters

Quick info box for display of:
- ETA to cursor position
- operator instructions
- Date / Time
- Stop watch



TRACKBALL for left- or right-hand operation



TRACKPILOT control panel with joystick

The Trackball includes a large DO button for activating operator settings. Either one or the two smaller buttons may be used for additional functions.

Standard Functions

- Additional display for
 - RADARSCOPE
 - DOCKING display
 - Wind display
 - Echosounder profile
- Automatic anti clutter function
CLEAN SWEEP
- Two metric DOCKING ranges of 250 and 500 m
- 80 ARPA/AIS targets
- 400 AIS sleeping targets
- Full target data display on two selected targets or short readout of eight ARPA/AIS targets
- Display of "bow cross distance"
- Path prediction of ship's motion
- Event marker with storage of position, time and type
- Print screen function via CHARTPILOT 1100
- Max "look ahead" function

- Changing between true and relative presentation, without losing the trail information
- Two independent EBL and VRM
- Four parallel index lines
- Four sectors for radar blanking
- Curved headline (version with TRACKPILOT only)
- Display of ETA to cursor position
- Trackball for interactive left- or right hand operation

Antenna rotation 23/28 rpm										
Range [NM]	0.25***	0.50	0.75	1.5	3	6	12	24	48	96
Short pulse	0.08		0.15		0.30	0.50	0.90*/1.0**			
Pulse length [µs]	2000		1000		500					
PRF [Hz]	0.15		0.30	0.50	0.90*/1.0**					
Long pulse	1000		500							
Pulse length [µs]	2000		1000		500					
PRF [Hz]										
Antenna rotation 46/56 rpm										
Range [NM]	0.25***	0.50	0.75	1.5	3	6	12	24	48	96
Short pulse	0.08		0.15		0.30	0.50				
Pulse length [µs]	2000		1000		1000					
PRF [Hz]	0.15		0.30	0.50						
Long pulse	1000		1000							
Pulse length [µs]	2000		1000		500					
PRF [Hz]										

* 12.5 kW X-Band Transceiver
 ** 25 kW X-Band and 30 kW S-Band Transceiver
 *** the given figures are also valid for 250 and 500 m range

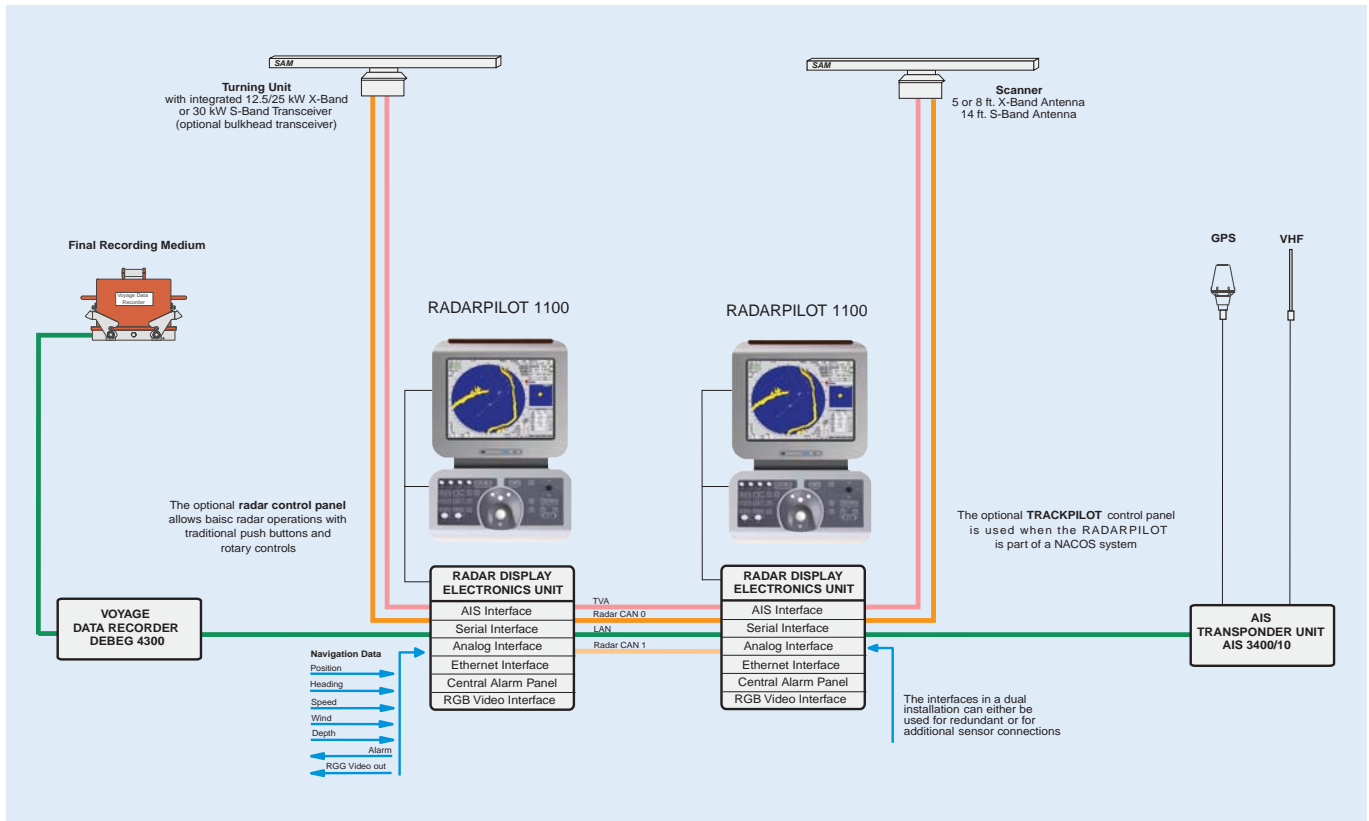

Typical dual RADAR installation with VDR and AIS integration

Technical and Installation Data

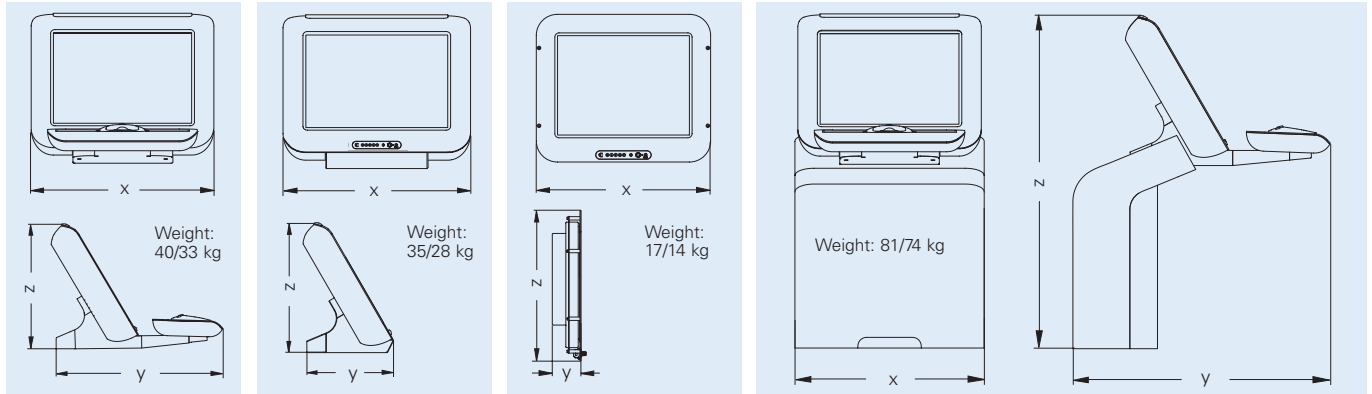

C5 Desktop unit with integrated control panel

C5 Desktop monitor without control panel

C5 Console monitor

C5 Console unit with integrated control panel and display electronics

RADARPILOT 1100 basic versions

Characteristics		Dimensions [mm]											
		C5 Console unit			C5 Desktop unit			C5 Desktop monitor			C5 Console monitor		
Category	Size	x	y	z	x	y	z	x	y	z	x	y	z
CAT 2	19" TFT	650	887	85	516	690	432	516	344	436	515	88	441
CAT 1	23" TFT	650	887	68	630	690	516	630	344	519	630	102	534

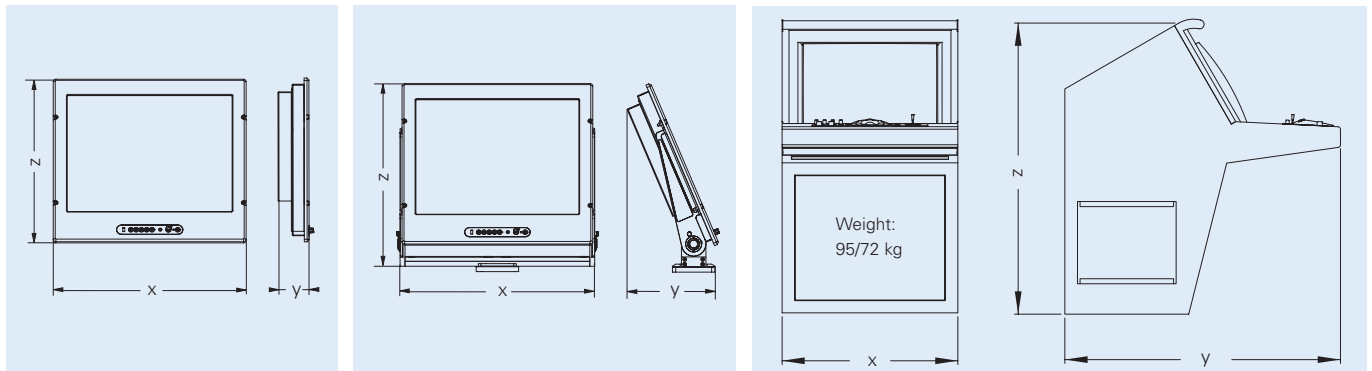

C4 Console monitor

C4 Desktop monitor

C4 Console unit with integrated control panel and display electronics

RADARPILOT 1100 basic versions

Characteristics		Dimensions [mm]								
		C4 Console unit			C4 Console monitor			C4 Desktop monitor		
Category	Size	x	y	z	x	y	z	x	y	z
CAT 2	19" TFT	550	1090	1150	483	82	404	489	130	493
CAT 1	23" TFT	700	1090	1150	584	97	495	615	130	576

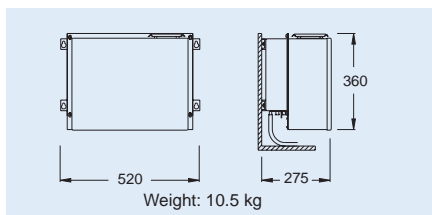

Display electronics

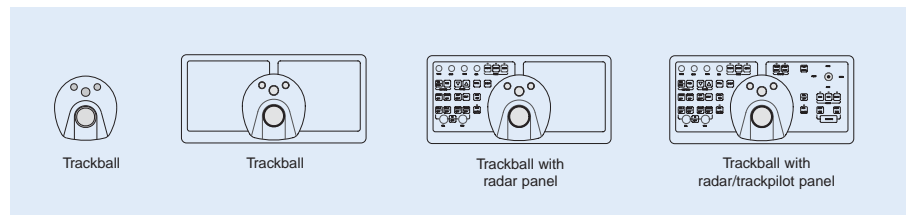

Control panels

Technical and Installation Data

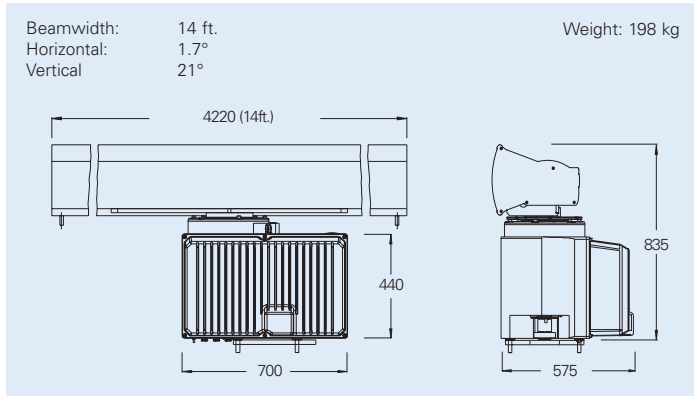

S-Band Antenna Unit, Type GR3041, with integrated performance monitor and 30 kW* S-Band transceiver, optional 30kW* bulkhead transceiver, type NG3041

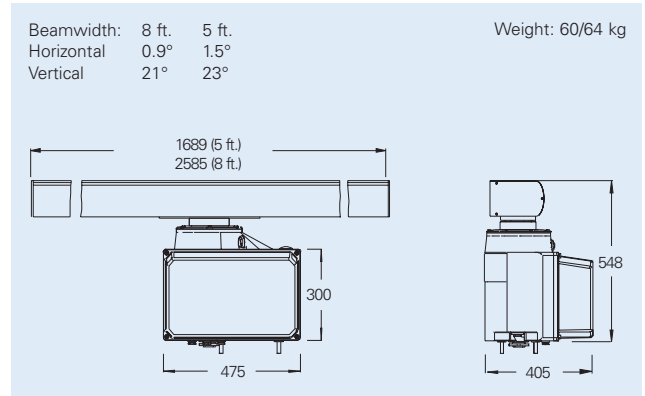

X-Band Antenna Unit, Type GR3040, with integrated performance monitor and 12.5 or 25 kW* X-Band transceiver, optional 25 kW* bulkhead transceiver, type NG3040

AC voltage**	1x	1x	3x	3x	3x	Power Cons. [VA]	HSC Mode
frequency	115 V	230 V	230 V	400 V	450 V		
X-Band antenna unit, type GR 3040		•	•	•	•	250/460***	•
S-Band antenna unit, type GR 3041		•	•	•	•	1300/1700***	•
X/S-Band transceiver, type NG3040/41	•	•				150	

* Magnetron peak power (nominal)

** Tolerances according to IEC 60945

*** The higher consumption only applies to high speed antenna units

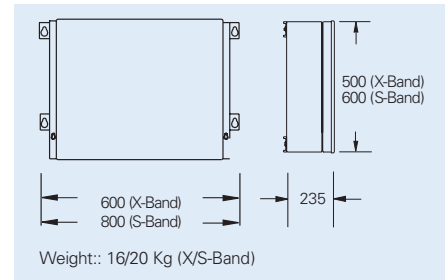

Bulkhead transceiver, type NG3040 (X-Band) and NG3041 (S-Band)

Operational conditions and protection (according to IEC 60945, extract): below deck units: max. -15°C to +55°C (for reasons of lifetime, a constant ambient temperature of approx. 20°C, ±5°C should be maintained) above deck units: max. -25°C to +55°C (+70°C for storage)